



**Technical Service  
BULLETIN**

October 27, 2007

Title:

**M.I.L. "ON" DTC P0171, P030#, AND/OR  
P0133 ENGINE RUNNING LEAN IN  
SUBFREEZING AMBIENT  
TEMPERATURES**

Models:

**'00 – '05 Celica (1ZZ-FE)**

**ENGINE  
EG046-07**

**Introduction** Following a cold soak in subfreezing ambient temperatures, some 2000 – 2005 model year Celica vehicles equipped with a 1ZZ-FE engine may exhibit a M.I.L. "ON" with one or more of the following Diagnostic Trouble Codes (DTCs) as the result of a vacuum leak at the intake manifold.

- P0171 – System Too Lean (Bank 1)
- P0300 – Random Multiple Cylinder Misfire Detected
- P030# – Cylinder (1–4) Misfire Detected
- P0133 – Oxygen Sensor Slow Response (Bank 1 Sensor 1)

Please use the following procedure to repair the vehicle.

**Applicable  
Vehicles**

- **2000 – 2005** model year **Celica** vehicles equipped with the **1ZZ-FE engine**.

**Parts  
Information**

PREVIOUS PART NUMBER	CURRENT PART NUMBER	PART NAME	QTY
17171-22030	17171-22060	Gasket, Intake Manifold to Head, No. 1	1

**Warranty  
Information**

OP CODE	DESCRIPTION	TIME	OFF	T1	T2
170051	R & R Intake Manifold Gasket	1.6	17171-22030	04	13

**Applicable Warranty\*:**

- This repair is covered under the Toyota Federal Emission Warranty. This warranty is in effect for 36 months or 36,000 miles, whichever occurs first, from the vehicle's in-service date.\*\*
- For California specification vehicles sold, registered, and operated in California, Maine (starting with 2004 model year), Massachusetts, and Vermont, this repair is covered under the California Emission Warranty, which is in effect 36 months or 50,000 miles, whichever occurs first, from the vehicle's in-service date.

\* Warranty application is limited to correction of a problem based upon a customer's specific complaint.

\*\* Due to a misprint in the *Owner's Warranty Information* booklets, the Warranty Department will honor claims under the 60 months or 60,000 mile Powertrain Warranty for 2000 – 2004 model year vehicles.



**Required  
Tools &  
Equipment**

REQUIRED EQUIPMENT	SUPPLIER	PART NUMBER	QTY
<b>TIS techstream*</b> NOTE: Software version 2.20.015 or later is required. 	ADE	TSUNT	1

\* Essential SST.

**NOTE:**

- Additional Techstream units may be ordered by calling Approved Dealer Equipment (ADE) at 1-800-368-6787.
- The Toyota Diagnostic Tester and CAN Interface Module may also be used to perform the service procedures listed in this bulletin.

**Inspection  
Procedure****NOTE:**

The vehicle **MUST** be diagnosed following a cold soak. If the vehicle is at operating temperature, the condition will **NOT** be present.

1. Monitor the following Data List parameter: Short FT #1 (Short Term Fuel Trim for Bank 1).

Using TIS techstream, select:

*Connect to Vehicle/Engine and ECT/Data List/Short FT #1.*

2. Following conventional diagnostic procedure, confirm if there is a leak where the intake manifold and cylinder head meet between each intake runner.

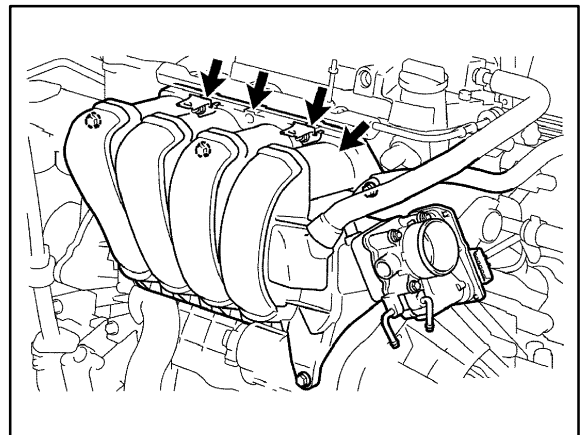

3. Did the short term fuel trim change to a rich reading (negative fuel trim) in step 2?
  - If **YES** — Replace the intake manifold gasket.
  - If **NO** — Check for other vacuum leaks or lean running conditions per the Technical Information System (TIS).

**Repair  
Procedure**

1. Drain the engine coolant.

Refer to TIS:

- 2000, 2001, or 2002 model year Celica Repair Manual, *Engine/Hybrid System – Cooling – "1ZZ–FE 2ZZ–GE: Coolant: Replacement"*
- 2003, 2004, or 2005 model year Celica Repair Manual, *Engine/Hybrid System – Cooling – "Coolant: Replacement"*

2. Remove the air cleaner assembly.

3. Disconnect the accelerator cable.

4. Remove the intake manifold.

- A. Disconnect the throttle position sensor connector.

- B. Disconnect the IAC valve connector.

- C. Disconnect the PCV hose from the throttle body.

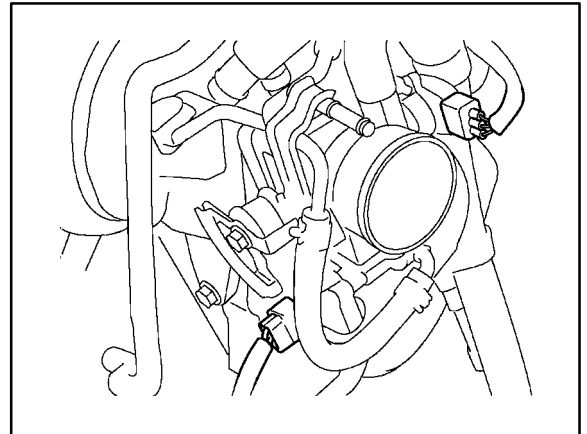

- D. Disconnect the 2 water bypass hoses.

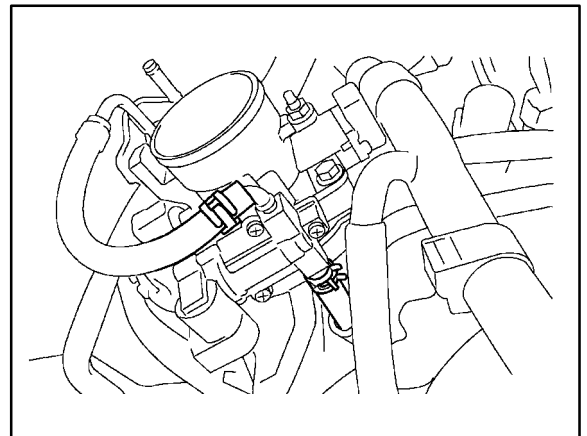

**Repair  
Procedure**  
(Continued)

- E. Disconnect the EVAP hose for ORVR.
- F. Disconnect the brake booster vacuum hose.
- G. Remove the 4 bolts, 2 nuts, intake manifold, 2 wire harness stays, and gasket.

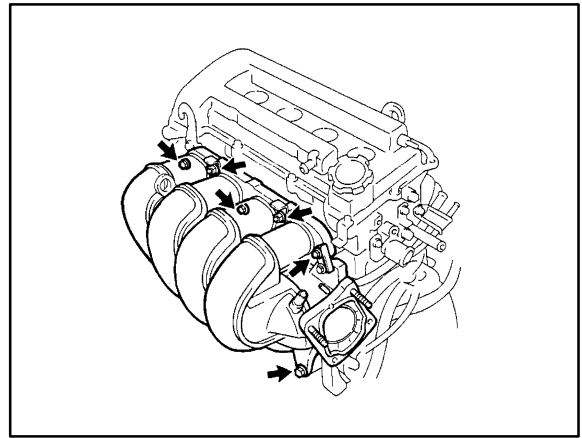

5. Clean the mounting surface of the intake manifold.
6. Install the intake manifold.
  - A. Install a NEW gasket, 2 wire harness stays and the intake manifold with the 4 bolts and 2 nuts. Uniformly tighten the bolts and nuts in several passes.  
**Torque: 30 N•m (306 kgf•cm, 22 ft•lbf)**
  - B. Connect the brake booster vacuum hose.
  - C. Connect the EVAP hose for ORVR.
  - D. Connect the 2 water bypass hoses to the throttle body.
  - E. Connect the IAC connector.
  - F. Connect the throttle position sensor connector.
  - G. Connect the PCF hose to the throttle body.
7. Reconnect the accelerator cable.
8. Reinstall the air cleaner assembly.
9. Fill and check the engine coolant.  
Refer to TIS:
  - 2000, 2001, or 2002 model year Celica Repair Manual, *Engine/Hybrid System – Cooling – “1ZZ–FE 2ZZ–GE: Coolant: Replacement”*
  - 2003, 2004, or 2005 model year Celica Repair Manual, *Engine/Hybrid System – Cooling – “Coolant: Replacement”*
10. Clear the fuel trim values by disconnecting the negative (–) battery cable for 90 seconds.
11. Test drive the vehicle and confirm normal operation.